

Molex 43879-0022 PDF

深圳创唯电子有限公司

<http://www.molex-connect.com>



PRODUCT SPECIFICATION

MINI-FIT JR. AND PLUS HCS CONNECTOR SYSTEM COMPLIANT PIN INTERFACE (CPI) (WIRE TO PCB & PCB TO PCB)

1.0 SCOPE

This specification covers the 4.20 mm / (.165 in.) centerline (pitch) Mini-Fit Jr. Compliant Pin Interface (Mini-Fit CPI™) dual row connector system in wire to board and board to board applications.

2.0 PRODUCT DESCRIPTION

2.1 PRODUCT NAME AND PART NUMBER

<u>Product Name</u>	<u>Part Number</u>
Minifit Jr Female Terminal	5556-****
Minifit Plus HCS Female Terminals	45750-****
Receptacle (dual row)	5557-****
BMI Receptacle Header (dual row)	42385-****
BMI Receptacle (dual row)	42474-****
CPI Vertical Header	43879-****

2.2 DIMENSIONS, MATERIALS PLATINGS & MARKINGS

See the appropriate sales drawings for the information on dimensions, materials, platings and markings.

3.0 APPLICABLE DOCUMENTS AND SPECIFICATIONS

See sales drawings and the other sections of this specification for the necessary referenced documents and specifications.

3.1 AGENCY APPROVALS

UL File #E29179
CSA Certificate #LR 19980

REVISION: 6	ECR/ECN INFORMATION: EC No: UCP2013-0617 DATE: 2013/08/08	TITLE: PRODUCT SPECIFICATION MINI-FIT JR. AND PLUS HCS CONNECTOR SYSTEM COMPLIANT PIN INTERFACE (CPI)	SHEET No. 1 of 6
DOCUMENT NUMBER: PS-43879-001	CREATED / REVISED BY: NNGUYEN	CHECKED BY: BELL	APPROVED BY: SMITH-ROEMER



PRODUCT SPECIFICATION

4.0 RATINGS

4.1 VOLTAGE RATINGS

UL / CSA 600 VOLTS AC (RMS) / DC

4.2 CURRENT RATINGS**

5556 Mini fit Jr Brass or Phosphor Bronze terminals with Tin or Gold Plating

	Ckt. Size / Wire Awg.	2	4 - 6	7 - 10	12 - 24
Maximum Rated Current Wire to Board	16 Awg	8 Amps	7 Amps	6 Amps	5 Amps
	18 Awg	8 Amps	7 Amps	6 Amps	5 Amps
	20 Awg	6 Amps	5 Amps	4 Amps	4 Amps
	22 Awg	4 Amps	3 Amps	3 Amps	3 Amps
	24 Awg	3 Amps	2 Amps	2 Amps	2 Amps
	26 Awg	2 Amps	1 Amps	1 Amps	1 Amps
	28 Awg	1 Amps	1 Amps	1 Amps	1 Amps
Header to Header	Ckt. Size	2	4 - 6	7 - 10	12 - 24
	Current	8 Amps	7 Amps	6 Amps	6 Amps

45750 Mini fit Plus HCS terminals with Tin or Gold Plating

	Ckt. Size / Wire Awg	2	4	6, 8	10, 12	14, 16, 18	20, 22, 24
Maximum Rated Current Wire to Board	16 Awg	11.5 Amps	9.5 Amps	9 Amps	8 Amps	8 Amps	7.5 Amps
	18 Awg	10 Amps	8.5 Amps	7.5 Amps	7 Amps	7 Amps	6.5 Amps
	20 Awg	9 Amps	8 Amps	7 Amps	6.5 Amps	6 Amps	5.5 Amps

** Ratings shown represent *MAXIMUM* current carrying capacity of a fully loaded connector with all circuits powered. Ratings are based on a 30°C maximum temperature rise limit over ambient (room temperature). Testing conducted with tinned copper conductor stranded wire. Above charts are intended as a guideline. Current rating is application dependent. Appropriate de-rating is required depending on factors such as higher ambient temperature, smaller copper weight of PCB traces, gross heating from adjacent modules or components and other factors that influence connector performance.

REVISION: 6	ECR/ECN INFORMATION: EC No: UCP2013-0617 DATE: 2013/08/08	TITLE: PRODUCT SPECIFICATION MINI-FIT JR. AND PLUS HCS CONNECTOR SYSTEM COMPLIANT PIN INTERFACE (CPI)	SHEET No. 2 of 6
DOCUMENT NUMBER: PS-43879-001	CREATED / REVISED BY: NNGUYEN	CHECKED BY: BELL	APPROVED BY: SMITH-ROEMER



PRODUCT SPECIFICATION

4.3 TEMPERATURES

Operating:* -40 Degrees C to +105 Degrees C
 Nonoperating: -40 Degrees C to +105 Degrees C
 *(Including 30 degrees C terminal temperature at full current)

Note: The Mini-Fit CPI™ connector system was not designed or tested for either current sharing or hot plugging (mating and unmating of live circuits). Use of this connector system in these types of applications is not recommended and is not within the scope of this product specification.

5.0 PERFORMANCE

5.1 ELECTRICAL PERFORMANCE

Section	Item	Test Condition	Requirement
5.1.1	Initial Contact Resistance (low level)	Mate connectors, measure by dry circuit, 20mV max., 100mA. Wire resistance shall be removed from the measured value.	10 mΩ max.
5.1.2	Insulation Resistance	Mate connectors, apply 500V AC for 1 minute adjacent terminal or ground.	1000 MΩ min.
5.1.3	Dielectric Strength	Mate connectors, apply 1500V AC for 1 minute between adjacent terminal or ground.	No breakdown.
5.1.4	Compliant Pin Interface Resistance	Insert individual Compliant Pin terminal into printed circuit board.	1.0 mΩ max.

REVISION: 6	ECR/ECN INFORMATION: EC No: UCP2013-0617 DATE: 2013/08/08	TITLE: PRODUCT SPECIFICATION MINI-FIT JR. AND PLUS HCS CONNECTOR SYSTEM COMPLIANT PIN INTERFACE (CPI)	SHEET No. 3 of 6
DOCUMENT NUMBER: PS-43879-001	CREATED / REVISED BY: NNGUYEN	CHECKED BY: BELL	APPROVED BY: SMITH-ROEMER



PRODUCT SPECIFICATION

5.2 MECHANICAL PERFORMANCE

Section	Item	Test Condition	Requirement
5.2.1	Contact Insertion and Withdrawal for 5556 terminals	Insert and withdraw a contact at a speed rate of 25± 6 mm / Minute	Max. Insertion = 1.5Kg. Min. Withdrawal = .01Kg.
5.2.2	Crimp Terminal Insertion Force	Insert the crimped terminal into the housing	Max. Insertion = 1.5Kg
5.2.3	Crimp Terminal Retention Force	Apply axial pull out force at a speed rate of 25± 6 mm/minute on the terminal inserted in the housing.	Min. Retention = 3.0Kg
5.2.4	Header Terminal Retention Force	Apply axial pull out force at a speed rate of 25± 6mm / minute on the terminal assembled in the housing.	Min. Retention = 1.0Kg
5.2.5	Wire Pull Out Force	Mount the crimped terminal, apply an axial pull out force on the wire at a speed rate of 25± 6mm / minute.	16 Awg = 7.0 Kg Min. 18 Awg = 7.0 Kg Min. 20 Awg – 6.0 Kg Min. 22 Awg = 4.0 Kg Min. 24 Awg = 3.0 Kg Min. 26 Awg = 2.0 Kg Min. 28 Awg = 1.0 Kg Min.
5.2.6	Normal Force for 5556 terminals	Apply a perpendicular force simultaneously to each beam to desired deflection at a speed rate of 25± 6 mm / minute.	150 g min.
5.2.7	Normal Force for 45750 Plus HCS	Apply a perpendicular force simultaneously to each beam to desired deflection at a speed rate of 25± 6 mm / minute.	360 g min.
5.2.8	Compliant Pin Insertion and Retention Force	Insert Compliant Pin terminal at a speed rate of 25± 6 mm / minute into printed circuit board.	Insertion = 20 Kg max. Withdrawal = 2 Kg min.
5.2.9	Panel Insertion & Withdrawal	Insert and withdraw a connector at a speed rate of 25± 6 mm / minute	Insertion = 23 Kg max. Withdrawal = 12 Kg min.
5.2.10	Durability for 5556 terminals	Insert and withdraw connectors (30 times) at a maximum rate of 10 cycles per minute prior to environmental tests.	Contact Res. Change = 20 mΩ max.

REVISION:	ECR/ECN INFORMATION:	TITLE:	SHEET No.
6	EC No: UCP2013-0617 DATE: 2013/08/08	PRODUCT SPECIFICATION MINI-FIT JR. AND PLUS HCS CONNECTOR SYSTEM COMPLIANT PIN INTERFACE (CPI)	4 of 6
DOCUMENT NUMBER:	CREATED / REVISED BY:	CHECKED BY:	APPROVED BY:
PS-43879-001	NNGUYEN	BELL	SMITH-ROEMER



PRODUCT SPECIFICATION

5.2 MECHANICAL PERFORMANCE (cont.)

Section	Item	Test Condition	Requirement
5.2.11	Durability for 45750 terminals*	Per EIA-364-09C, mate connectors 100 cycles for tin plated product, 250 cycles for gold plated product at a maximum rate of 500 cycles per hour.	10 mΩ Max. chg. from Initial; Visual: No Damage
5.2.12	Vibration for 5556 terminals	Amplitude: 1.50 mm peak to peak Sweep: 10-50-10 Hz in one minute Duration: 2 hours in each X-Y-Z axis.	Contact Res. Change = 20 MΩ max. Discontinuity not greater than 1 μsecond.
5.2.13	Vibration (Random) for 45750 terminals	EIA 364-28: Mate connectors and vibrate per, test condition VII, Letter D. 15 minutes in each axis	10 mΩ Max. chg. from Initial; Discontinuity < 1 microsecond
5.2.14	Mechanical Shock with 5556 terminals	50 G's with three saw tooth wave form shocks in each X-Y-Z axis	Contact Res. Change = 20 mΩ max. Discontinuity not greater than 1 μsecond

* Durability ratings established as tested per Durability Test Procedures described by EIA-364-09C and meet requirements for low level contact resistance and DWV as prescribed per EIA-364-1000 Test Sequence Group 7.

5.3 ENVIRONMENTAL PERFORMANCE

Section	Item	Test Condition	Requirement
5.3.1	Cold Resistance with 5556 terminals	-40± -3°C for 96 hrs.	Appearance: No damage Contact Res. Change =20mΩ max.
5.3.2	Thermal Shock	Mate connectors, expose to 10 cycles of: -55 +0-3°C for 30 minutes +105± 10°C for 5 minutes max.	Appearance: No damage Contact Res. Change =20mΩ max.
5.3.3	Thermal Aging with 5556 terminals	Mate connectors, expose to 96 hours at 105 ±2°C	Appearance: No damage Contact Res. Change =10 mΩ max.
5.3.4	Thermal Aging with 45750 terminals	Mate connectors, expose to 240 hours at 105 ±2°C	Appearance: No damage Contact Res. Change =10 mΩ max.

REVISION: 6	ECR/ECN INFORMATION: EC No: UCP2013-0617 DATE: 2013/08/08	TITLE: PRODUCT SPECIFICATION MINI-FIT JR. AND PLUS HCS CONNECTOR SYSTEM COMPLIANT PIN INTERFACE (CPI)	SHEET No. 5 of 6
DOCUMENT NUMBER: PS-43879-001	CREATED / REVISED BY: NNGUYEN	CHECKED BY: BELL	APPROVED BY: SMITH-ROEMER



PRODUCT SPECIFICATION

5.3 ENVIRONMENTAL PERFORMANCE (cont.)

Section	Item	Test Condition	Requirement
5.3.5	Humidity (Steady State) with 5556 terminals	Mate connectors, expose to a temperature of 60±2°C with a relative humidity of 90% to 95% for 96 hours.	Appearance: No damage Contact Res. Change = 20 mΩ max. Dielectric withstanding voltage: No breakdown Insul res. 1000MΩ min
5.3.6	Immunity to Fretting Corrosion (thermal cycling)	Mate connectors, expose to 500 cycles with a max. transition time of 5 minutes between extremes. +25±10°C for 30 minutes +70+3/-0°C for 30 minutes	Appearance: No damage Contact Res. Change: =20mΩ max.
5.3.7	Temp. Rise & Current Cycling	Mate the connectors and measure the temperature rise at the rated current for 96 hrs., 45 minutes ON and 15 minutes OFF for 240 hrs., and an additional 96 hrs. of steady-state current.	Max. Temp. Rise = 30°C above ambient.

6.0 PACKAGING

Parts shall be packaged to protect against damage during handling, transit, and storage.

REVISION: 6	ECR/ECN INFORMATION: EC No: UCP2013-0617 DATE: 2013/08/08	TITLE: PRODUCT SPECIFICATION MINI-FIT JR. AND PLUS HCS CONNECTOR SYSTEM COMPLIANT PIN INTERFACE (CPI)	SHEET No. 6 of 6
DOCUMENT NUMBER: PS-43879-001	CREATED / REVISED BY: NNGUYEN	CHECKED BY: BELL	APPROVED BY: SMITH-ROEMER

NO OF CKTS	PARTS PER TRAY	PARTS PER BOX (SPQ)	STD PACK QTY PER TRAY
4	85	680	8 TRAYS OF 85
6	70	560	8 TRAYS OF 70
8	60	480	8 TRAYS OF 60
10	50	400	8 TRAY OF 50
12	45	360	8 TRAYS OF 45
14	40	320	8 TRAYS OF 40
16	35	280	8 TRAYS OF 35
18	30	240	8 TRAYS OF 30
20	30	240	8 TRAYS OF 30
22	25	200	8 TRAYS OF 25
24	25	200	8 TRAYS OF 25

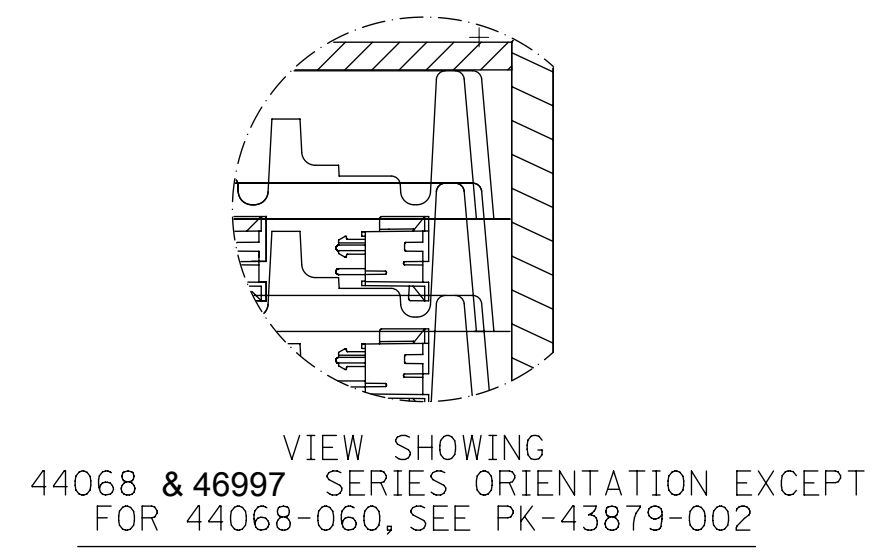
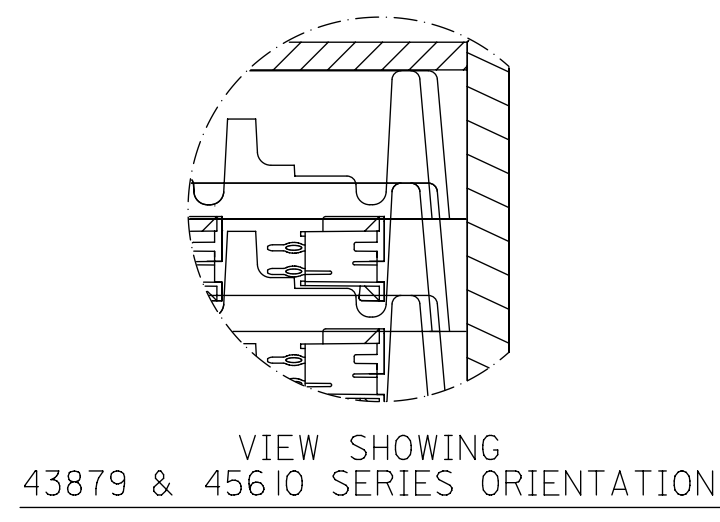
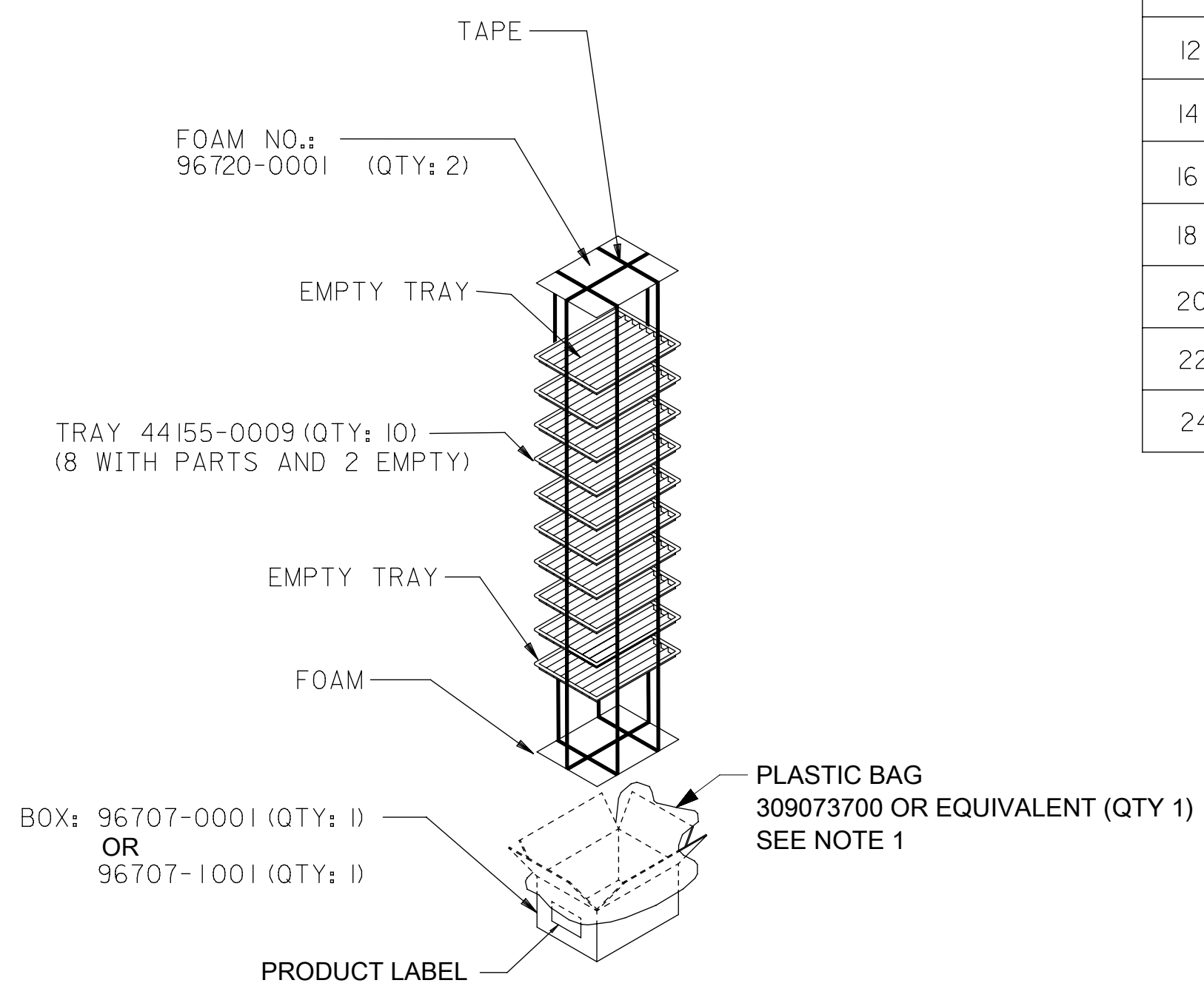
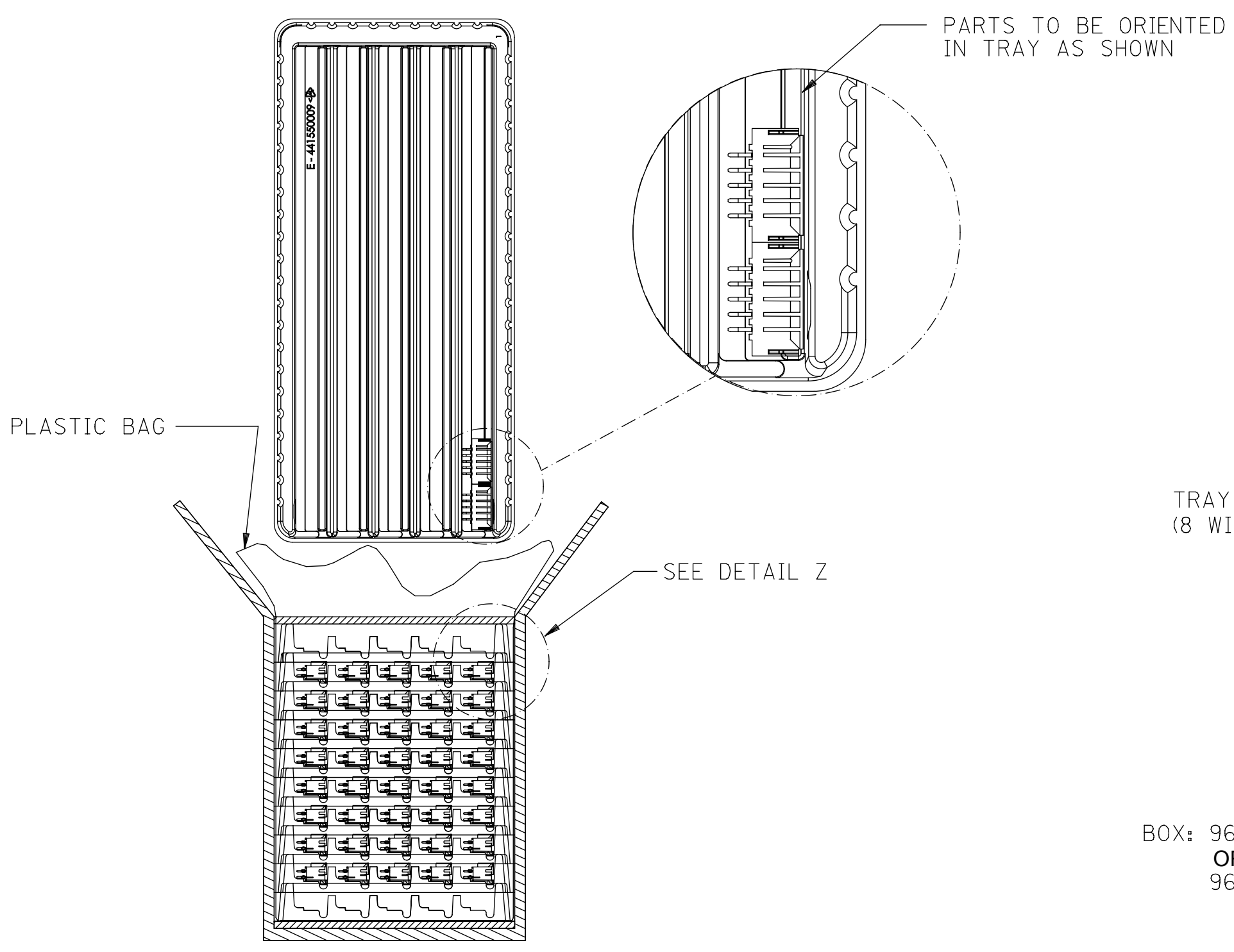

DETAIL "Z"
N.T.S.

NOTES:
1. TRAYS ARE TO BE PLACED IN A PLASTIC BAG AND SEALED WITH A TWIST TIE.

QUALITY SYMBOLS		THIS DRAWING CONTAINS INFORMATION THAT IS PROPRIETARY TO MOLEX ELECTRONIC TECHNOLOGIES, LLC AND SHOULD NOT BE USED WITHOUT WRITTEN PERMISSION		DIMENSION UNITS		SCALE				
▽ = 0	▽ = 0	GENERAL TOLERANCES (UNLESS SPECIFIED)		IN/MM	N/A	DATE				
▽ = 0	▽ = 0	ANGULAR TOL ± °		DRAWN BY		DATE		PACKAGING DESIGN DRAWING		
▽ = 0	▽ = 0	4 PLACES ±		SAMIEC		1998/12/12				
▽ = 0	▽ = 0	3 PLACES ±		CHK'D BY		DATE		DOCUMENT NUMBER: PK-43879-001 DOC TYPE: PDD DOC PART: 000 SHEET NUMBER: 1 OF 1		
▽ = 0	▽ = 0	2 PLACES ±		BANDURA		1998/12/12				
▽ = 0	▽ = 0	1 PLACE ±		APPR BY		DATE		EC NO: 110678 CHANGE BAG PIN 2016/12/01 2016/12/08 2016/12/15		
▽ = 0	▽ = 0	0 PLACES ±		FSMITH		2012/10/09				
□ = 0	■ = 0	DRAFT WHERE APPLICABLE MUST REMAIN WITHIN DIMENSIONS		DRAWING SIZE		THIRD ANGLE PROJECTION		D1		
▽ = 0				C						